

訂正日 DATE	訂正内容 REVISION	訂正者 REVISED BY
△×		
△×		
△×		

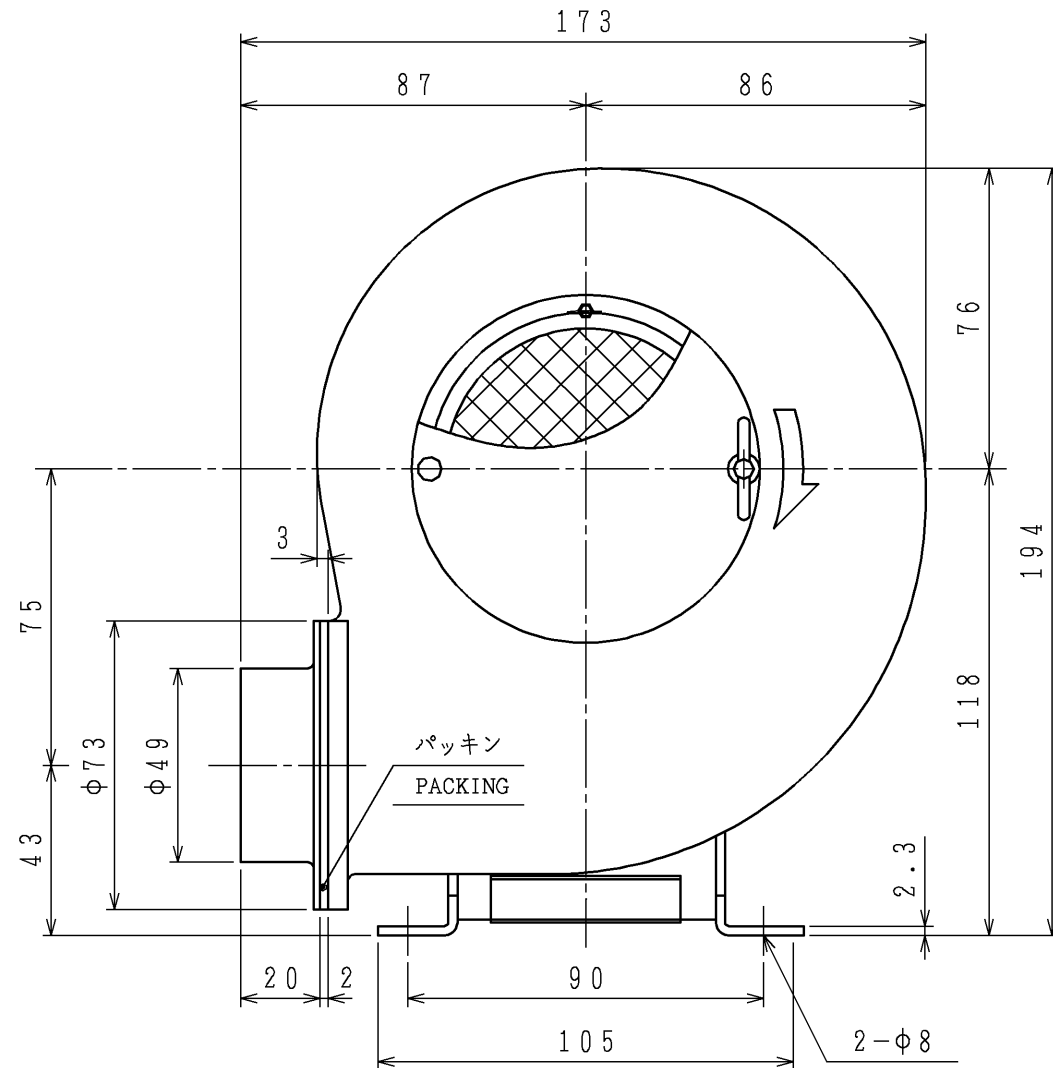
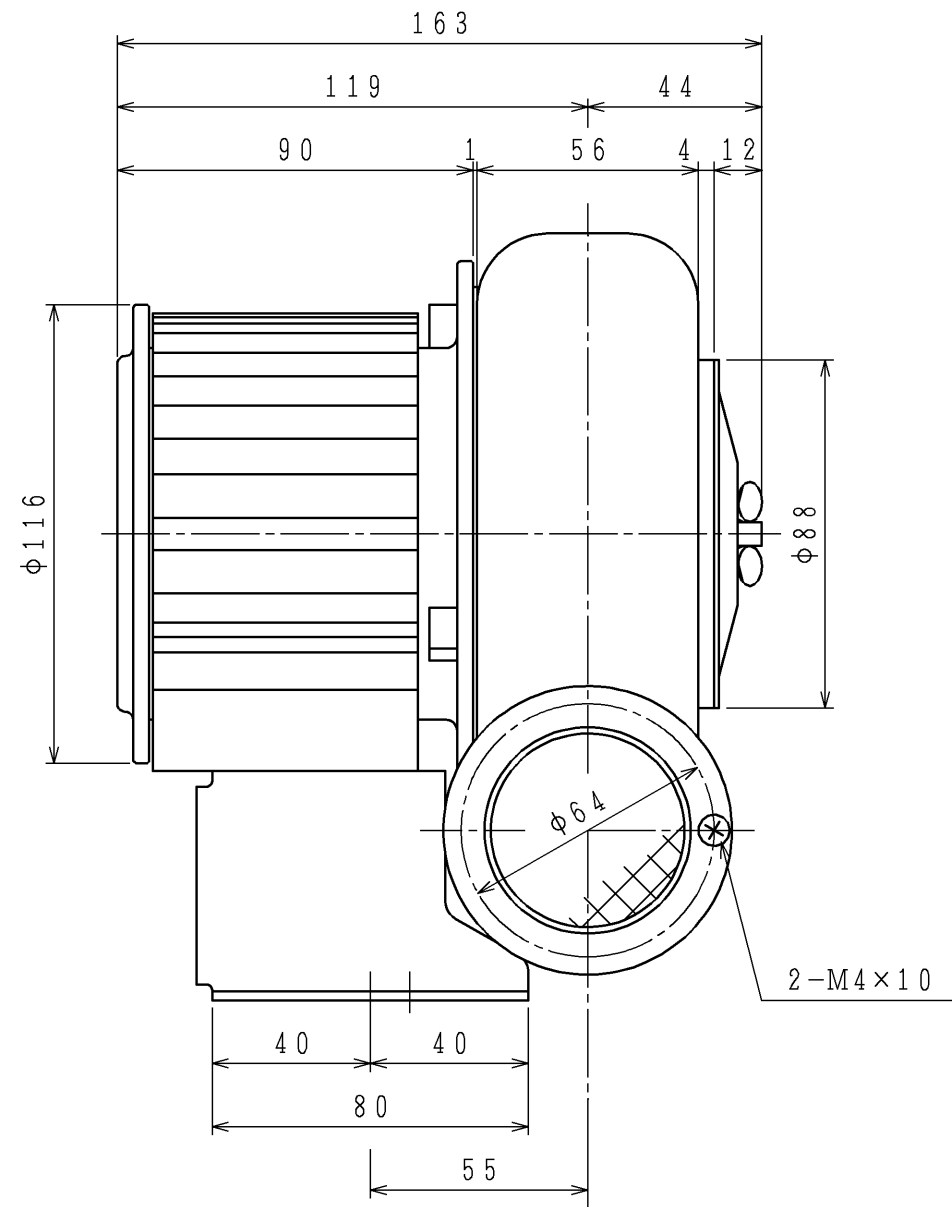

(01年型)  
(01MODEL)

4	吸込・吐出 溶接金網付 (4メッシュ d0.7) WITH SUCTION AND DISCHARGE WIRE NET (4 MESH d0.7)	
3	サーマルプロテクタ付 WITH THERMAL PROTECTOR	
2	保護方式 ENCLOSURE	全閉形 TOTALLY ENCLOSED TYPE
	出力 OUTPUT [kW]	0.04
	極数・相 POLES PHASE	2・1
	電圧 VOLTAGE [V]	100
	周波数 FREQUENCY [Hz]	50 60
1	風量(MAX.) VOLUME [m <sup>3</sup> /min]	2.2 2.6
	静圧(MAX.) [kPa] STATIC PRESSURE	0.32 0.45
	回転数 SPEED [min <sup>-1</sup> ]	2700 3200
	標準吸込状態 STANDARD SUCTION CONDITION	温度 TEMPERATURE 20℃ 湿度 HUMIDITY 65% 絶対圧 ABSOLUTE P. 101.3 kPa
仕様 SPECIFICATIONS		

 担当 DESIGN S. HATANO	作成日 DATE 2001.10.10 OCTOBER 10, 2001
尺度 SCALE 1:2 担当 DESIGN 検図 CHECK N. YANAGI	品名 TYPE SF-50-L3A3
 昭和電機株式会社 大東工場 SHOWA DENKI CO., LTD DAITO FACTORY	図名 TITLE 外形寸法図 DRAWING FOR EXTERNAL DIMENSIONS
	図番 DRAWING NO. NB03L3A300-0

図歴  
RECORDS



# 性能曲線図

## PERFORMANCE CURVE

作成 DATE	2002. 4. 24 APRIL 24, 2002
作成 DRAW	S. HATANO
承認 APPROVE	M. TANAKA

品名/形式 TYPE	SF-50-L3A3	電動機 MOTOR	0.04 kW	2 P
風量 VOLUME	MAX. 2.6 m <sup>3</sup> /min	電圧 VOLTAGE	100 V	
静圧 STATIC PRESSURE	MAX. 0.45 kPa	電流 CURRENT	0.8 A	
回転速度/回転数 FAN SPEED	3200 min <sup>-1</sup>	温度 TEMPERATURE	20 °C	密度 DENSITY 1.2 kg/m <sup>3</sup>
周波数 FREQUENCY	60 Hz			
備考 NOTES				

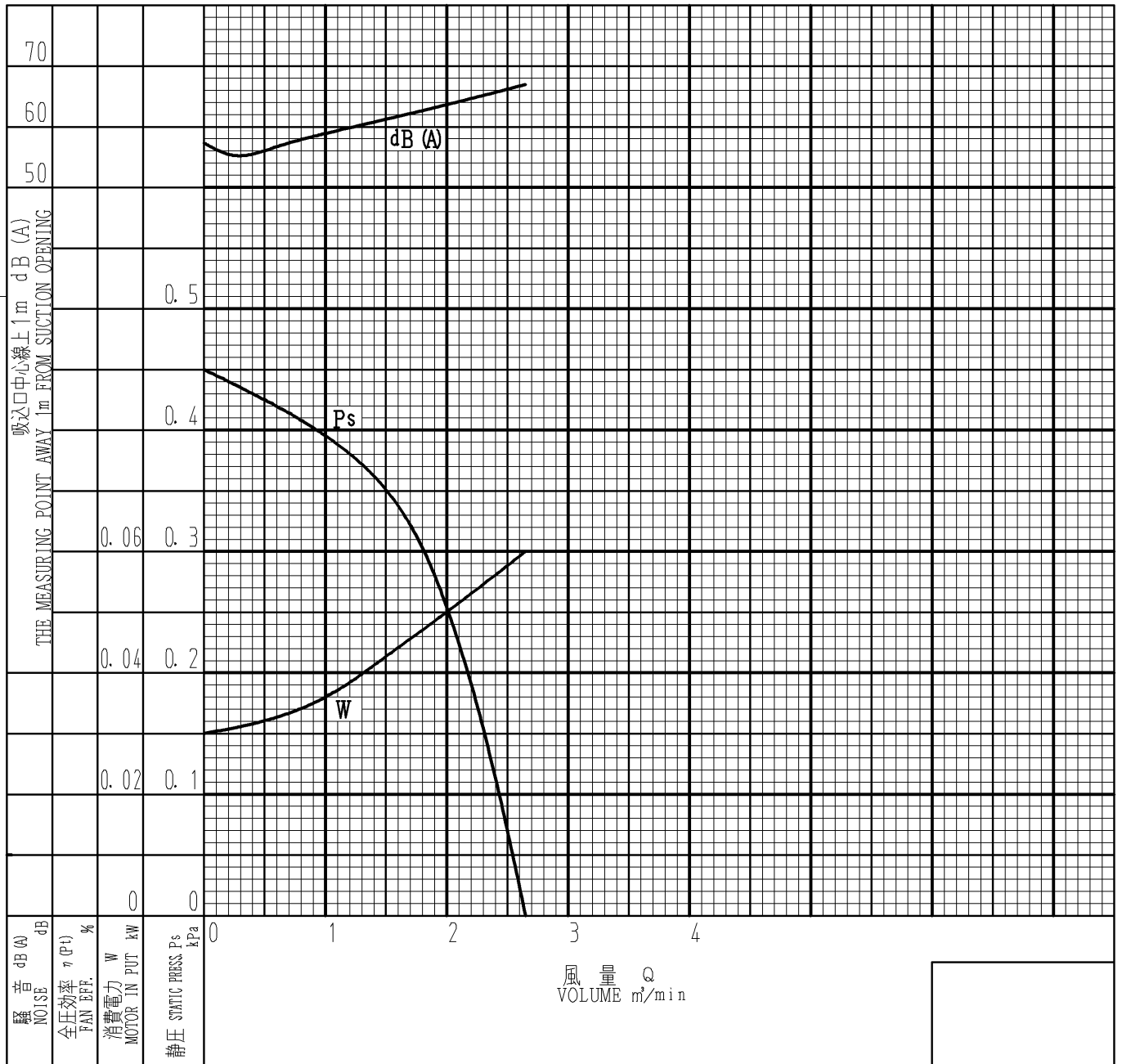

図番  
DWG. NO.

NB03L3A260-0

昭和電機株式会社 大東工場  
SHOWA DENKI CO., LTD DAITO FACTORY